

Drain valve 9209 and 9210

- Male thread 1/4" – 1/2"
- Drain valve with cap



Description

Drain valve.

Construction

Drain valve in brass with cap.
Connection male thread 1/4" - 1/2".
Body in various designs.

Model 9209
Seal in PTFE and gaskets in NBR.

Model 9210
Seal in PTFE and gaskets in EPDM and NBR.

Marking

DN.

Maintenance

The ball valve must be operated periodically, two to three times a year.

Technical data

Body	Brass CW617N
Ball seal	PTFE
Stem gaskets (model 9209)	NBR/NBR
Stem gasket (model 9210)	EPDM
Cap gasket	NBR

Maximum working pressure: 10 bar
Maximum working temperature: +100°C

Drain valve 9209 and 9210

9209-15

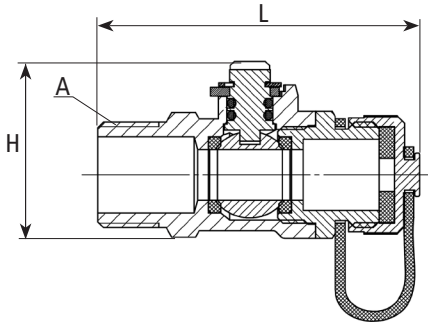

9210-8

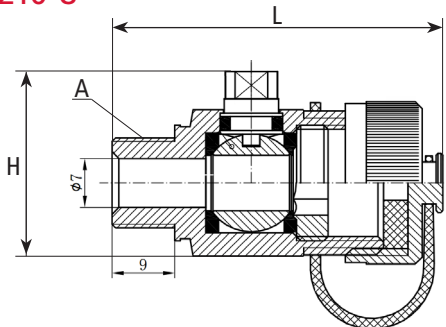

9210-15

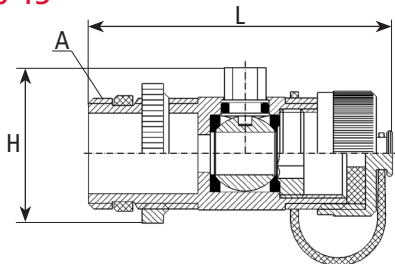

Item number	Description	Connection A	Length L	Centrum height H	Bore Ø	Weight (kg)
0492091500	Drain valve 9209, 1/2" M x 1/2" M, with cap	1/2" M	64	35	10	0,12
0492101508	Drain valve 9210, 1/4" M x 1/2" M, with cap	1/4" M x 1/2" M	45	27,5	7	0,12
0492101500	Drain valve 9210, 1/2" M x 1/2" M, with cap	1/2" M	54	28	7	0,10

All dimensions in millimetres

Subject to technical changes and corrections without notice